



Division of Erectoweld, Inc.

1444 S. West Ave., Waukesha, WI 53189
 Tel: 262-547-0211 Fax: 262-547-0718
 weedharvesters@aol.com

586 Third Line, Oakville, ON L7L 4A7 Canada
 Tel: 905-825-1371 Fax: 905-825-4116
www.aquamarine.ca info@aquamarine.ca

7385 Baldwin Rd., Cayuga, NY 13034
 Tel: 315-253-4270 Fax: 315-253-9277
 Weedharvesters.com
 hclasen@weedharvesters.com

SC-450 SHORE CONVEYOR (32’/9.75 m)
Technical Specifications

DIMENSIONS & WEIGHT

Length Overall (A)	41’-9”	12,73 m
Width Overall	8’-4”	2,54 m
Width Shipping	8’-0”	2,44 m
Height Towing	10’-0”	3,05 m
Height Shipping	7’-2”	2,19 m
Drop-off Height (C)	17’-0”	5,18 m
Weight w/o Options	4,850 lbs	2,570 kg

AXLE, INDEPENDENT SUSPENSION

Type	Single
GAWR	7,000 lbs 3,180 kg
Axle Width, O/A (B)	8’-0” 2,44 m
Rim Size	14.5 x 7, 5-bolt
Tires	9 – 14.5, 12-ply

CONVEYOR

Length (1)	32’-0”	9,75 m
Width	4’-2”	1,27 m
Conveyor Belting, Cleated	HD Galvanized Flat Wire Mesh	
Shafts Diameter	3”	76 mm
Hydraulic Motors	Two (2)	

HYDRAULIC POWER TRAIN

Gasoline Engine	Air-cooled, 13HP/9.7kW @ 3600 rpm, electric start
Fuel Tank	2.25 US gal 8.5 liters
Pump	Gear type
Control Valve	Two (2) stack, manual
Lift Cylinder	Single
Hydraulic Tank	12 US gal 45 liters

ACCESSORIES

Jack	7,000 lbs 3,180 kg
Pintle Eye Diameter	2.5” 65 mm
Safety Chains	Two (2)
Battery	Heavy duty 12-volt
Fasteners	Stainless steel
Conveyor Safety Bar	Standard equipment

ANTI-CORROSION SYSTEM:

High impact, high visibility safety orange, thermally cured epoxy coating

OPTIONAL EQUIPMENT

- Spare parts package with tire & wheel assembly
- Stainless Steel Structure
- Stainless steel belting
- Towing package: light bar & wire harness

(1) Extended version available in 2’0”/800 mm long increments. Shore conveyor can be shipped in 1-40’/12 m long open-top container. Some minor assembly required.

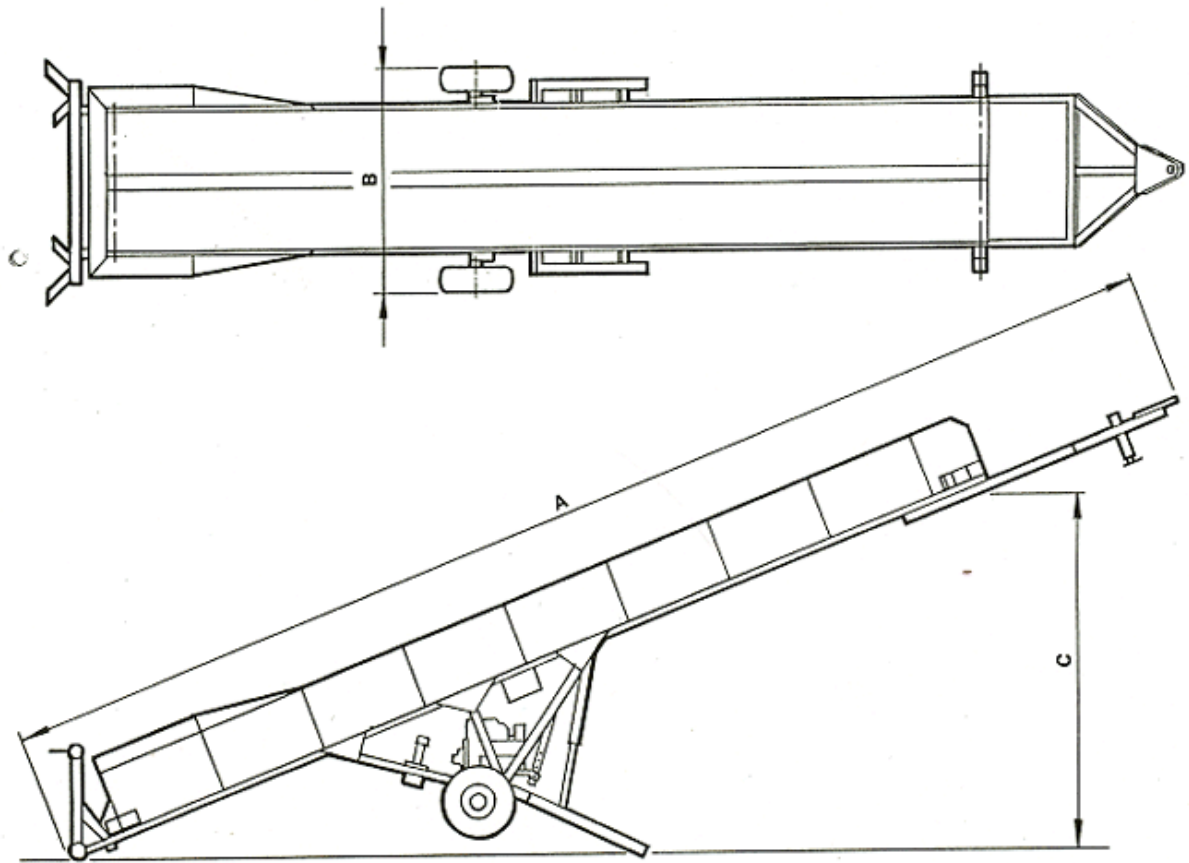

AQUAMARINE SC 450 SHORE CONVEYOR