



**Division of Erectoweld, Inc.**

1444 S. West Ave., Waukesha, WI 53189  
 Tel: 262-547-0211 Fax: 262-547-0718  
 weedharvesters@aol.com

586 Third Line, Oakville, ON L7L 4A7 Canada  
 Tel: 905-825-1371 Fax: 905-825-4116  
[www.aquamarine.ca](http://www.aquamarine.ca) info@aquamarine.ca

7385 Baldwin Rd., Cayuga, NY 13034  
 Tel: 315-253-4270 Fax: 315-253-9277  
 Weedharvesters.com  
 hclasen@weedharvesters.com

**SC-230 SHORE CONVEYOR (30’/9.15 m)**

**Technical Specifications**

**DIMENSIONS & WEIGHT**

Length Overall (A)	38’-0”	11,58 m
Width Overall (B)	8’-0”	2,44 m
Width Shipping	8’-0”	2,44 m
Height Towing	9’-6”	2,90 m
Height Shipping	7’-2”	2,19 m
Drop-off Height (C)	15’-0”	4,57 m
Weight w/o Options	3,700 lbs	1,680 kg

**AXLE, INDEPENDENT SUSPENSION**

Type	Single, with springs	
GAWR	7,000 lbs	3,180 kg
Axle Width, O/A (B)	8’-0”	2,44 m
Rim Size	14.5 x 7, 5-bolt	
Tires	9 – 14.5, 12-ply	

**CONVEYOR**

Length (1)	30’-0”	9,15 m
Width	3’-1”	0,94 m
Conveyor Belting, Cleated	Std. Galvanized Flat Wire Mesh	
Shafts Diameter	3”	76 mm
Hydraulic Motors	Two (2)	

**HYDRAULIC POWER TRAIN**

Gasoline Engine	Air-cooled, 10.5 HP/7.83 kW @ 3600 rpm, electric start	
Fuel Tank	0.75 US gal	2.85 liters
Pump	Gear type	
Control Valve	Two (2) stack, manual	
Lift Cylinder	Single	
Hydraulic Tank	6 US gal	22.7 liters

**ACCESSORIES**

Jack	7,000 lbs	3,180 kg
Pintle Eye Diameter	2.5”	65 mm
Safety Chains	Two (2)	
Battery	Heavy duty 12-volt	
Fasteners	Stainless steel	
Conveyor Safety Bar	Standard equipment	

**ANTI-CORROSION SYSTEM:**

High impact, high visibility safety orange, thermally cured epoxy coating

**OPTIONAL EQUIPMENT**

- Spare parts package with tire & wheel assembly
- Stainless Steel Structure
- Stainless steel belting
- Towing package: light bar & wire harness

(1) Extended version available in 2’0”/600 mm long increments.

(2) Note: Shore conveyor can be shipped in 1-40’/12 m long open-top container. Some minor re-assembly required.

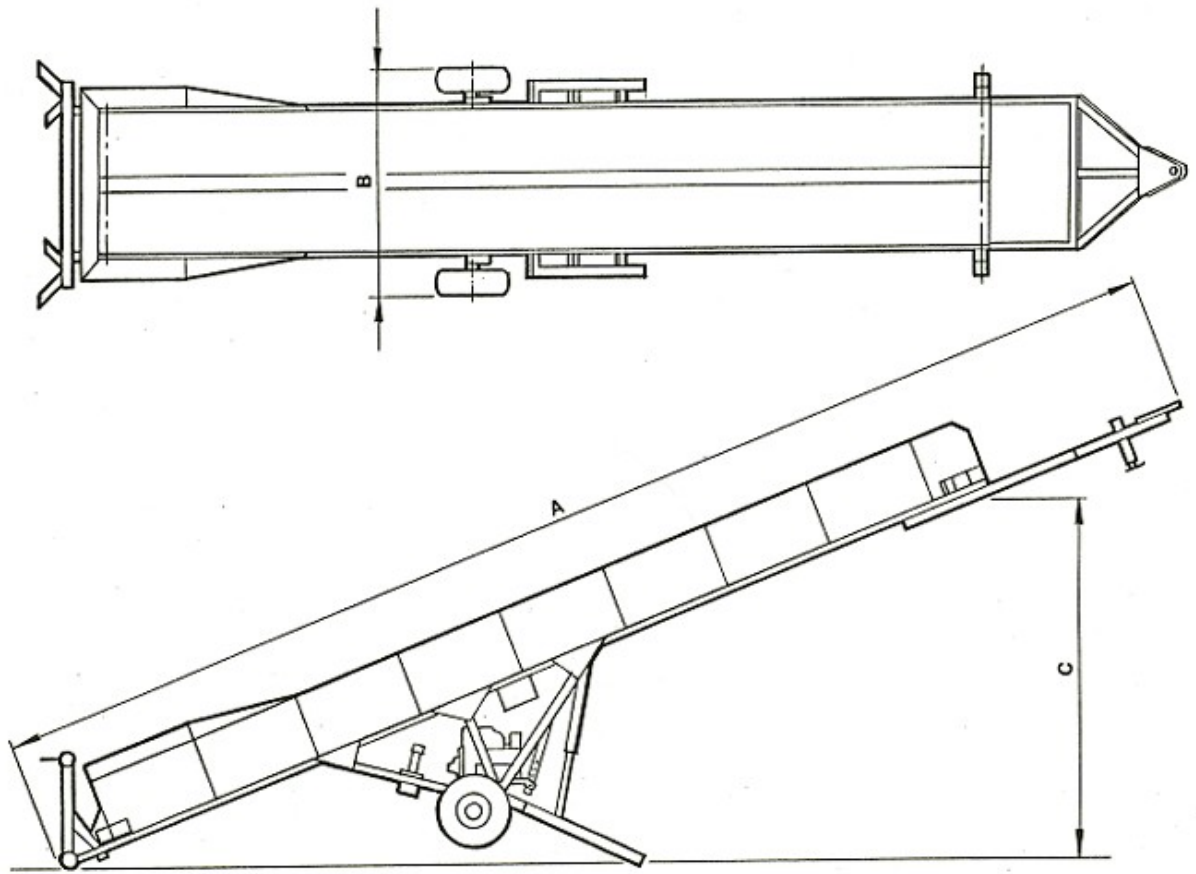

**AQUAMARINE** SC130 & SC-230 SHORE CONVEYORS