



DIVISION OF ERECTOWELD, INC.

1444 South West Ave., Waukesha WI 53189
262-547-0211 Fax 262-547-0718
weedharvesters@aol.com

586 Third Line, Oakville, ON L7L 4A7 Canada
Tel: (905) 825-1371 Fax: (905) 825-4116
www.aquamarine.ca

7385 Baldwin Rd., Cayuga NY 13034
315-253-4270 Fax: 315-253-9277
Weedharvesters.com atcc@localnet.com

SC-130 SHORE CONVEYOR (30'/9.15m)

Technical Specifications

DIMENSIONS & WEIGHT

Length Overall (A)	38'-0"	11,58 m
Width Overall (B)	7'-0"	2,13 m
Width Shipping	7'-0"	2,13 m
Height Towing	9'-6"	2,90 m
Height Shipping	7'-2"	2,19 m
Drop-off Height (C)	15'-0"	4,57 m
Weight w/o Options	3,200 lbs	1,454 kg

AXLE, INDEPENDENT SUSPENSION

Type		Single
GAWR	5,200 lbs	2,360 kg
Axle Width, O/A (B)	7'-0"	2,13 m
Rim Size		14.5 x 7, 5-bolt
Tires		9 – 14.5, 12-ply

CONVEYOR

Length (1)	30'-0"	9,15 m
Width	2'-1"	0,64 m
Conveyor Belting, Cleated		Std. Galvanized Flat Wire Mesh
Shafts Diameter	3"	76 mm
Hydraulic Motors		One (1)

HYDRAULIC POWER TRAIN

Gasoline Engine	Air-cooled, 10.5 HP/7.8 kW @ 3600 rpm, electric start	
Fuel Tank	0.9 US gal	3.3 liters
Pump		Gear type
Control Valve		Two (2) stack, manual
Lift Cylinder		Single
Hydraulic Tank	6 US gal	22 liters

ACCESSORIES

Jack	7,000 lbs	3,180 kg
Pintle Eye Diameter	2.5"	65 mm
Safety Chains		Two (2)
Battery		Heavy duty 12-volt
Fasteners		Stainless steel
Conveyor Safety Bar		Standard equipment

ANTI-CORROSION SYSTEM:

High impact, high visibility safety orange, thermally cured epoxy coating

OPTIONAL EQUIPMENT

- Spare parts package with tire & wheel assembly
- Stainless Steel Structure
- Stainless steel belting
- Towing package: light bar & wire harness

(1) Extended version available in 2'0"/800 mm long increments. Shore conveyor can be shipped in 1-40'/12 m long open-top container. Some minor assembly required.

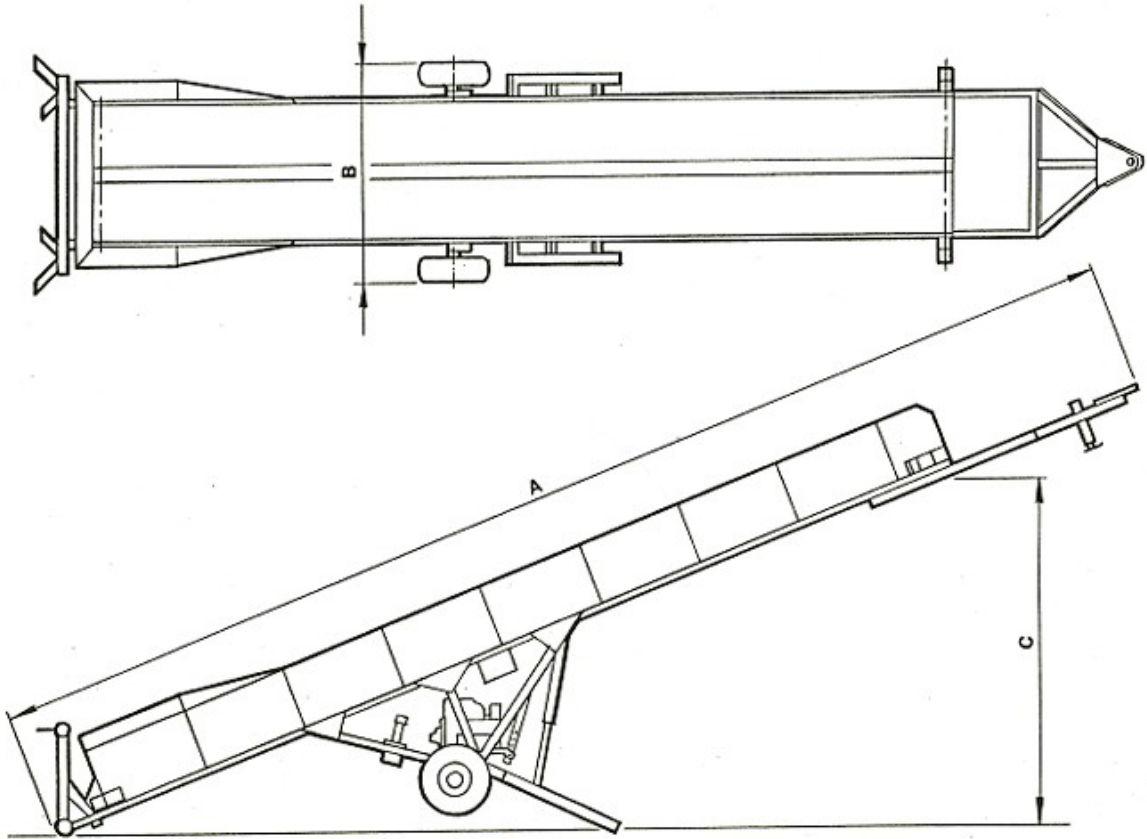

AQUAMARINE SC130 & SC-230 SHORE CONVEYORS