



**Division of Erectoweld, Inc.**

1444 S. West Ave., Waukesha, WI 53189  
 Tel: 262-547-0211 Fax: 262-547-0718  
 weedharvesters@aol.com

586 Third Line, Oakville, ON L7L 4A7 Canada  
 Tel: 905-825-1371 Fax: 905-825-4116  
[www.aquamarine.ca](http://www.aquamarine.ca) info@aquamarine.ca

7385 Baldwin Rd., Cayuga, NY 13034  
 Tel: 315-253-4270 Fax: 315-253-9277  
 Weedharvesters.com  
 hclasen@weedharvesters.com

**SC-1000 SHORE CONVEYOR (36'/10.9m)**

**Technical Specifications**

**DIMENSIONS & WEIGHT**

Length Overall (A)	45'-7"	13,89 m
Width Overall	10'-10"	3,30 m
Width Shipping	8'-0"	2,44 m
Height Towing	10'-0"	3,05 m
Height Shipping	7'-8"	2,34 m
Drop-off Height (C)	17'-0"	5,18 m
Weight w/o Options	7,000 lbs	3,182 kg

**AXLE, INDEPENDENT SUSPENSION**

Type	Single	
GAWR	7,000 lbs	3,180 kg
Axle Width, O/A (B)	8'-0"	2,44 m
Rim Size	14.5 x 7, 5-bolt	
Tires	9 – 14.5, 12-ply	

**CONVEYOR**

Length (1)	36'-0"	10,97 m
Width	6'-2"	1,88 m
Conveyor Belting, Cleated	HD Galvanized Flat Wire Mesh	
Shafts Diameter	3"	76 mm
Hydraulic Motors	Two (2)	

**HYDRAULIC POWER TRAIN**

Gasoline Engine	Air-cooled, 18HP/13.4kW @ 3600 rpm, electric start	
Fuel Tank	12 US gal	45 liters
Pump	Gear type	
Control Valve	Two (2) stack, manual	
Lift Cylinder	Single	
Hydraulic Tank	12 US gal	45 liters

**ACCESSORIES**

Jack	7,000 lbs	3,180 kg
Pintle Eye Diameter	2.5"	65 mm
Safety Chains	Two (2)	
Battery	Heavy duty 12-volt	
Fasteners	Stainless steel	
Conveyor Safety Bar	Standard equipment	

**ANTI-CORROSION SYSTEM:**

High impact, high visibility safety orange, thermally cured epoxy coating

**OPTIONAL EQUIPMENT**

- Spare parts package with tire & wheel assembly
- Stainless Steel Structure
- Stainless steel belting
- Towing package: light bar & wire harness

19/2/77

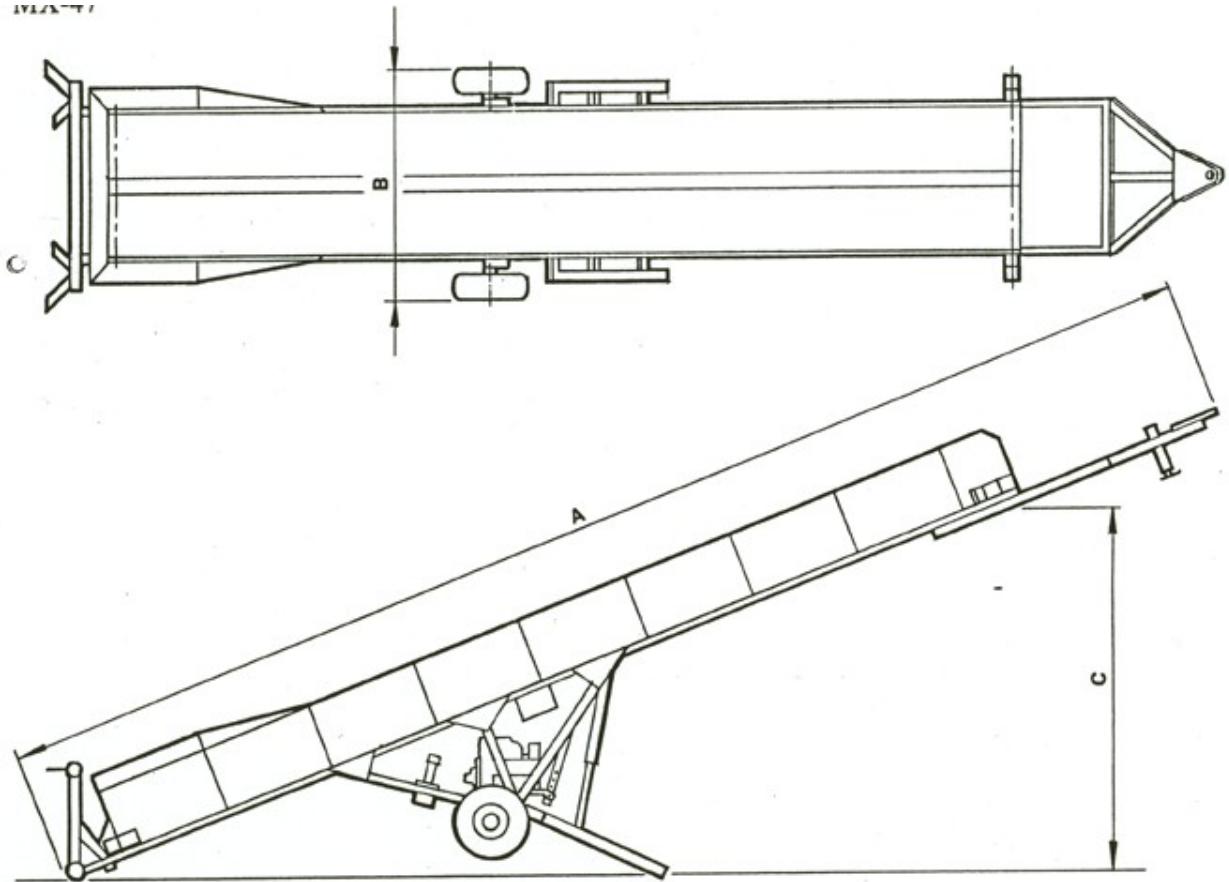

ETABLISSEMENT POLETTO  
BELLE VUE 47300 LE LEDAT FRANCE

Tel +33 553 403 184 Cel +33 681 379 074 Email [poletto@tele2.fr](mailto:poletto@tele2.fr)

SAUTERELLE  
SC-1000